

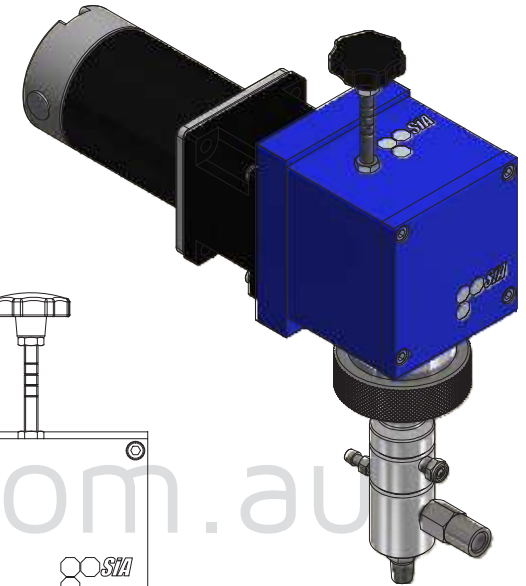

*Leading the world  
in chemical injection pump technology*

# **MANUAL INSTALLATION, OPERATION & MAINTENANCE**

**SiA CHEMICAL INJECTION PUMP**

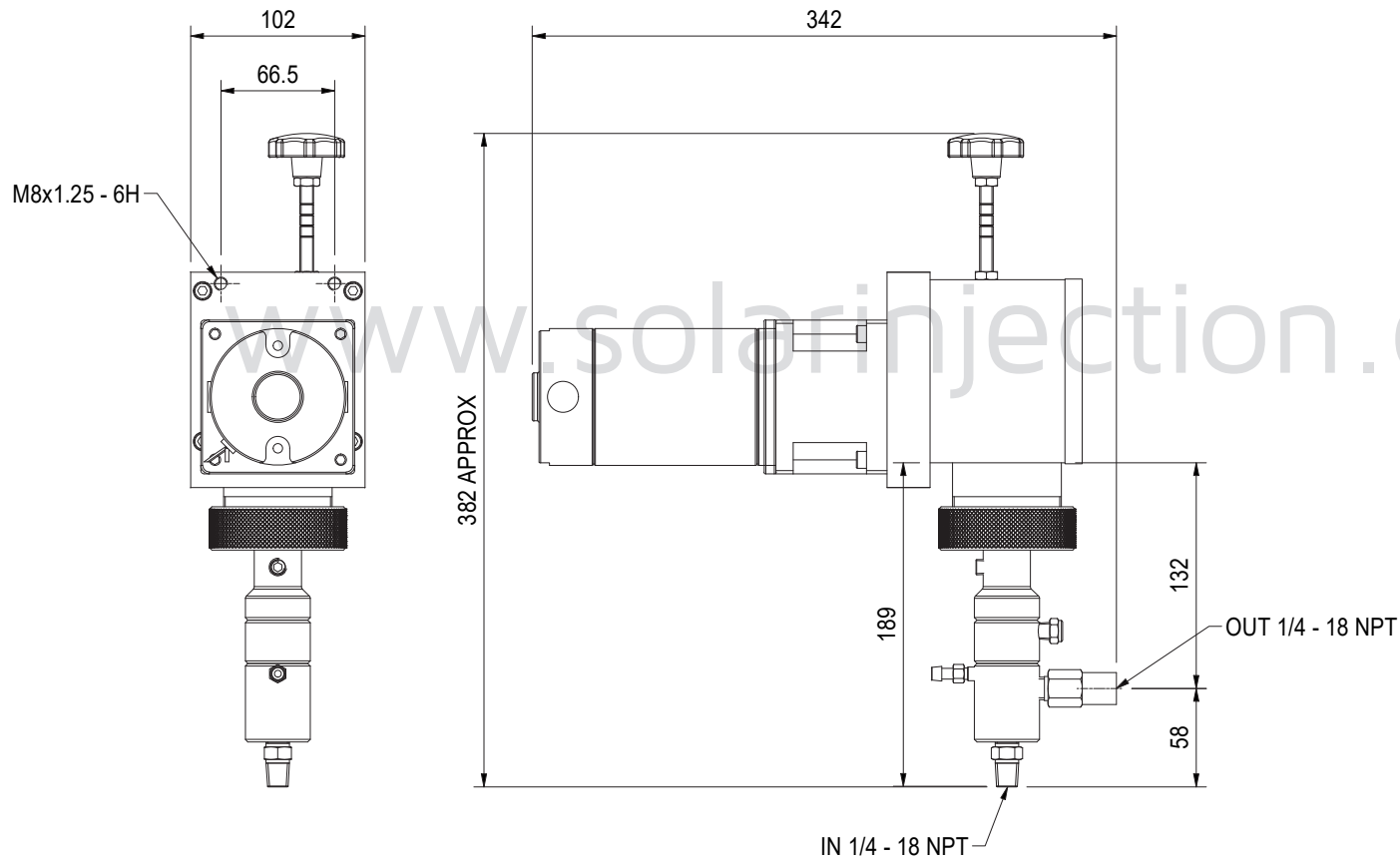

# ILLUSTRATION & PARTS LIST

SIA-24-L35-CR-TS-9050

Item	QTY	Description	Part Number	Material
1	1	DRIVE CASE	40042	6005 T5
2	1	MOTOR END PLATE	40044-1	Aluminum-6061
3	1	BEARING END PLATE	40047	Aluminum 6061
4	1	STROKE LENGTH ASSEMBLY	40084	
5	1	CRANK SHAFT 15 mm	40045-15	431 SS
6	1	Bearing	40023	
7	1	Bearing	40024	
8	1	BEARING	40032	
9	1	Circlip	40029	Steel, Mild
10	1	Circlip	40033	Steel, Mild
11	1	Pump Adaptor Legacy Series	40046-L	Aluminum 6061
12	1	PLUNGER ADAPTOR UPPER	40043	Ertalyte TX
13	4	Cylinder Head Cap Screw	40011-16	Steel, Mild
14	4	Cylinder Head Cap Screw	40011-10	Steel, Mild
15	1	GEARBOX 50:1, 24 VDC 90w MOTOR	40069-24-9050	

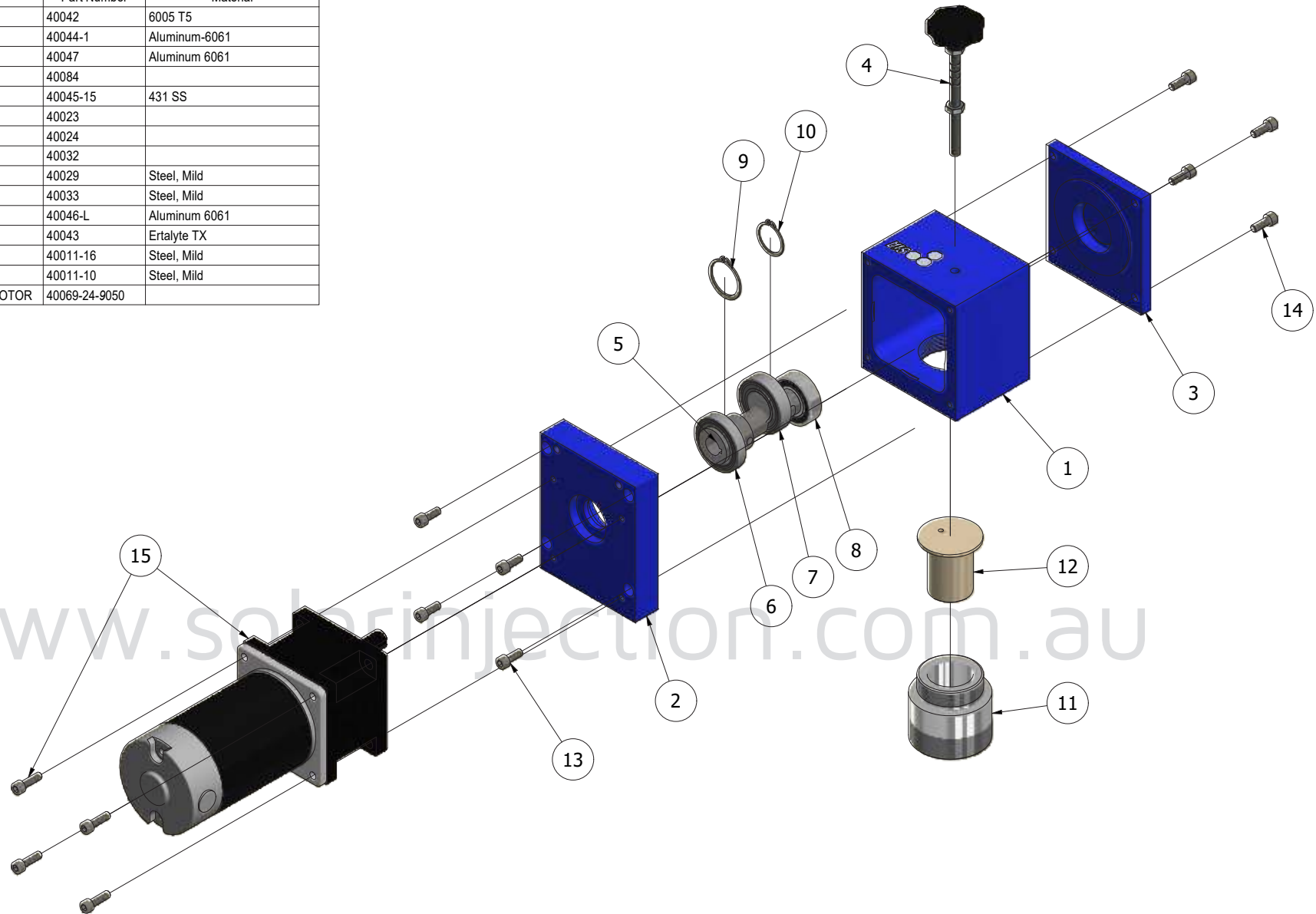

www.solarinjection.com.au

# ILLUSTRATION & PARTS LIST

SIA-24-L35-CR-TS-9050

Item	QTY	Description	Part Number	Material
1	1	FLANGE - LEGACY SERIES	40057	316 SS
2	1	PUMP ADAPTOR RING	40058	316 SS
3	1	PLUNGER ADAPTOR LOWER - LEGACY 0.25 UNC	40008-L	Ertalyte Tx
4	1	PLUNGER CERAMIC 0.375"	40066-2	CERAMIC
5	1	INLET CHECK VALVE 1/4"	40130-M	
6	1	BLEED VALVE	40064	316 SS
7	1	LUBE PLUG	40068	316 SS
8	1	PUMP BODY UPPER	40061	316 SS
9	1	PUMP BODY MIDDLE	40060	316 SS
10	2	O-RING VITON	40067-021	Viton
11	1	PUMP BODY LOWER	40059	316 SS
12	1	MAIN SEAL UHMWPE 0.375"	40065-2-2	UHMWPE
13	1	1/8" NPT VENT SCREEN	40089-40 Rev 10	ASTM A 240 316L
14	1	CHECK VALVE	40063-B	
15	2	BACKUP 0.375"	40055-2	DELTRIN
16	1	MAIN SEAL 0.375"	40065-2-4	UHMWPE
17	1	RETURN SPRING	40056	Steel

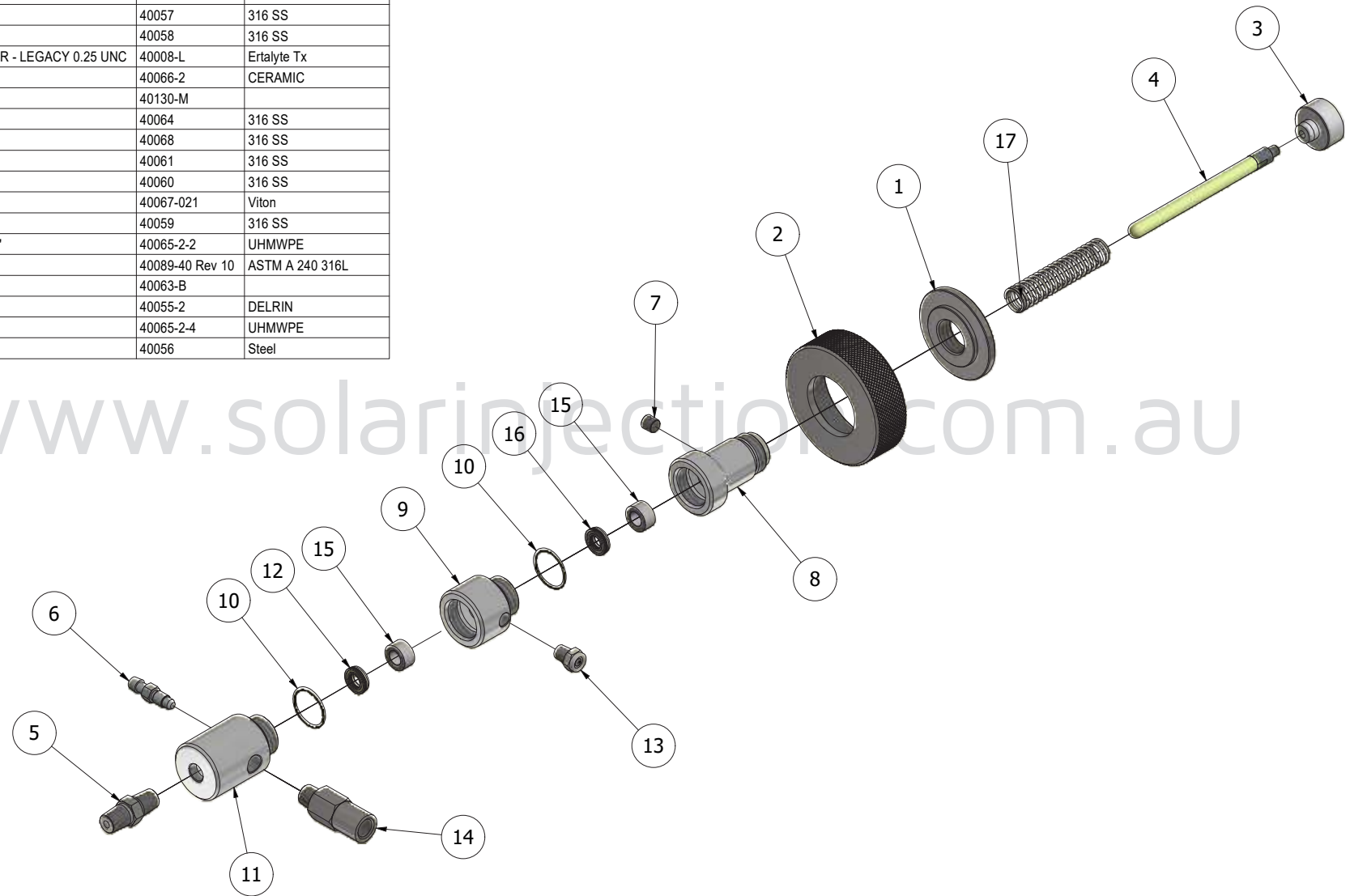

www.solarinjection.com.au

# TABLE OF CONTENTS

ILLUSTRATION & PARTS LIST .....	2
SECTION 1 GENERAL DESCRIPTION .....	6
1.0 Drive Assembly .....	6
1.1 Liquid End .....	7
1.2 Motor End .....	7
SECTION 2 INSTALLATION .....	8
2.0 Fuses .....	8
2.1 Mounting, Orientation & Environment .....	9
2.2 Installation - Step by Step .....	9
SECTION 3 PUMP OPERATION .....	10
3.0 Operating Pump With SiA Timer/Controller .....	10
3.1 Chemical Injection Flow Rate Adjustment .....	14
SECTION 4 MAINTENANCE .....	15
4.0 Routine Maintenance: Drive Assembly .....	15
4.1 Routine Maintenance: Liquid End .....	16
4.2 Routine Maintenance: Gearmotors fitted to the drive .....	17
4.3 Corrective Maintenance .....	16

# SECTION 1 GENERAL DESCRIPTION

## 1.0 Drive Assembly

### Drive Assembly Main Components

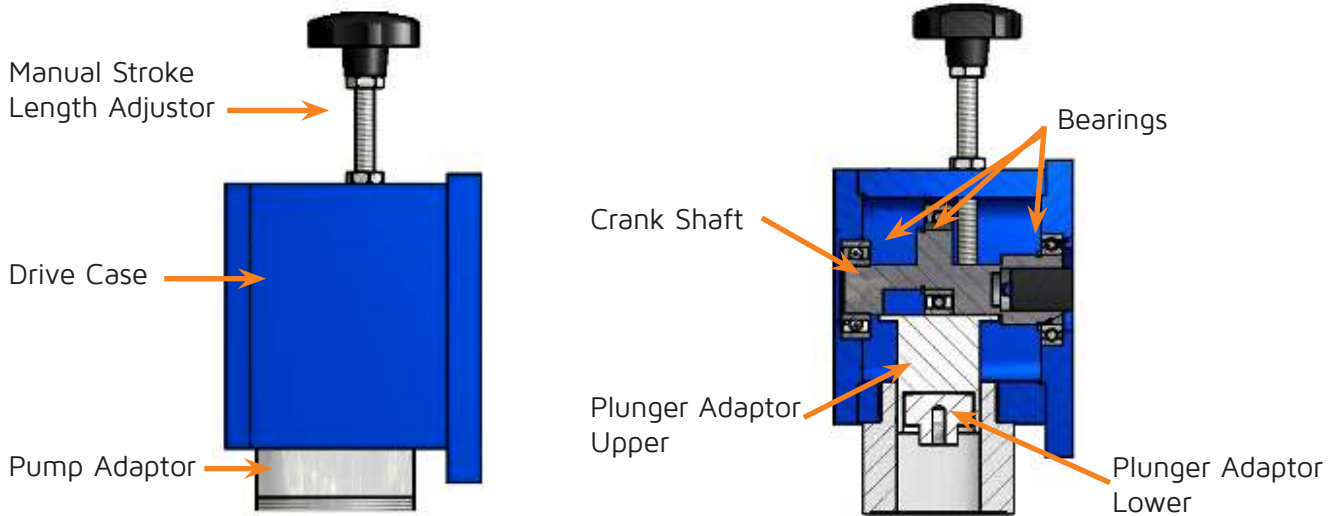

### 1.01 How the Drive Works

The SiA Drive Assembly has been designed to give a reliable means of driving a reciprocating chemical injection pump by means of electricity in general, and solar energy in particular.

The standard motive force of the Drive Assembly consists of a PMDC, BLDC or A.C. motor driving through an integrally mounted gearbox. This gear-motor mounts directly to the drive case's flange mount and the drive shaft connects to the drive crank shaft via a keyed connection. The crank shaft is supported either end by oversized sealed bearings so as to eliminate all overhung loads. This greatly increases the life of the gear-motor's gearbox.

By applying a rotary force to the end of the crank shaft, the force is transmitted to the pump by way of the plunger adaptor, which is directly acting on the pump plunger.

### Multiplex Drive Configuration

The SiA multiplex configuration works as described above, with the added benefit of allowing combined or multiple separate chemical flows in the one chemical injection pump.

### Liquid End Configurations

Simplex— One liquid end per drive case with Stroke Adjustment.

Duplex— Two liquid ends per drive case without Stroke Adjustment

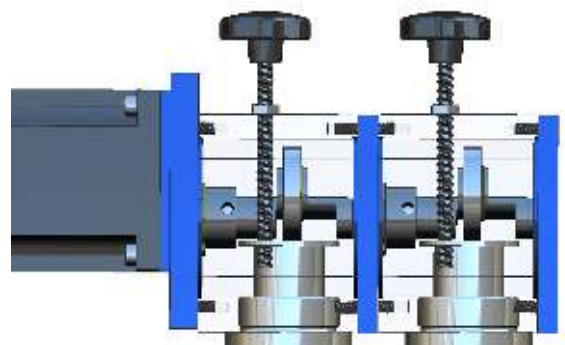

Multiplex 2 Configuration



Duplex Configuration

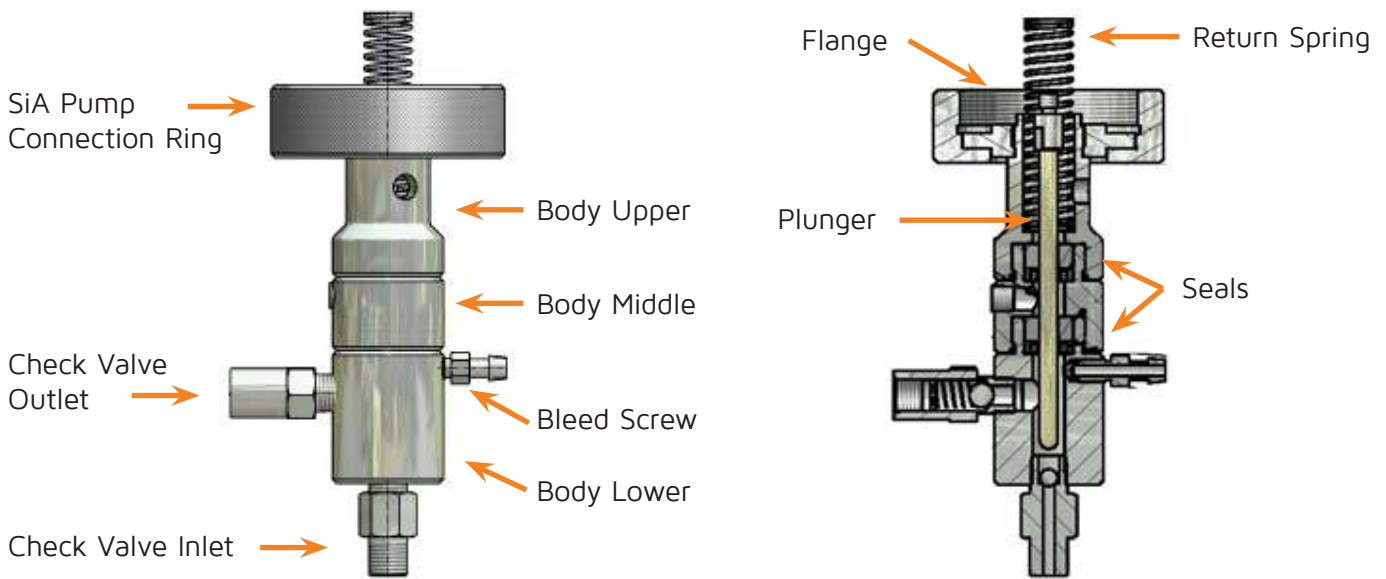

## 1.1 Liquid End

### Liquid End Main Components



## 1.2 Motor & Gearbox

A number of motor/gearbox options are available with SiA pumps depending on your application's requirements. The table below provides an outline of these different options, refer to the Parts List at the front of this manual for part numbers specific to your pump.

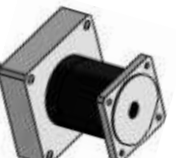
	Voltage	Watts	Ratio	Gearbox Type	Hazardous Area Certifications
 Standard	12; 24; 120/240; 220/415;	20; 40; 60; 90; 120; 150;	50; 75; 150	Spur	N/A
 Standard BLDC	12; 24;	100; 120; 200; 400;	40; 50;	Spur	N/A
 Heavy Duty (Motor Optional)	12; 24; 120/240; 220/415;	Motor Dependent	26; 32	Planetary	IECex; ATEX; UL/CSA

## SECTION 2 INSTALLATION

### 2.0 Fuses (PLEASE READ BEFORE INSTALLING)

Always ensure the correct fuse is fitted and connections are as per diagrams below to prevent damage to the pump that could void warranty.

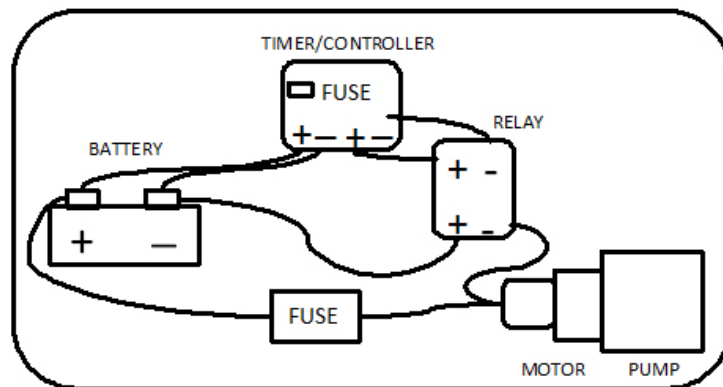
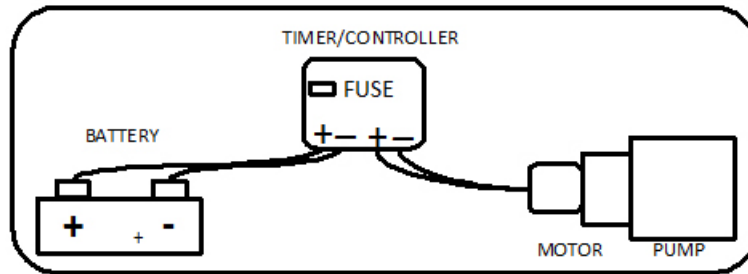

Always ensure the correct fuse is fitted and connections are as per diagrams below to prevent damage to the pump that could void warranty.

	Motor Wattage	FUUSE REQUIRED	
		12 Volt	24 Volt
High Efficiency	150 100 (IEC)	NA NA	7.5 amp 5 amp
Standard	40 60 90 120 150	5 amp 10 amp 15 amp 20 amp 25 amp	2.5 amp 5 amp 7.5 amp 10 amp 12.5 amp

For other wattage motors, or where no motor is supplied with the pump, please consult Solar Injection Australia to ensure correct fuse.

If the motor is being driven directly via an SIAT71500 Timer/Controller the maximum fuse rating is 10 amp.

Note: Drive case is limited to maximum input of 22 Nm, maximum of 150 Watts at 60 rpm. For loads above this, our Heavy Duty Drive should be used.



## 2.1 Mounting, Orientation & Environment

The preferred orientation for mounting is with the Liquid End pointing down, the Timer Module on top and the Gearmotor horizontal to the ground. This facilitates “bleeding” of the pump and maximises the life of the seals within the pump. The inlet of the Liquid End should be no higher than level with the lowest chemical level, to ensure a positive head on the inlet check valve. With Duplex configurations (ie 2 liquid ends on 1 drive), the Liquid Ends will be horizontal to the ground and the position of the inlet and outlet check valves will be reversed. Ensure that the inlet check valves, which are gravity-style, are facing downwards.

We recommend installing the assembly within a weatherproof enclosure. Where this is not practical, ensure as much weather and dust protection is afforded the whole assembly and the motor in particular. An SiA custom cover for the motor and gearbox assembly can be ordered separately if required.

Where environmental conditions are harsh, ie very wet, where there is salt water &/or dust or snow, consider coating the assembly with an appropriate coating or cover. In wet conditions in particular, we recommend use of a non hardening mastic on all mating parts, which is available as an option. Please contact Solar Injection Australia or an SiA Authorised Technical Agent before finalising the design of the installation.

Use the two M6 mounting holes to securely mount the assembly to any rigid frame or sub-assembly with mounting brackets (not supplied but available).

## 2.2 Installation — Step by Step

1. Discard all plastic closures on the Liquid End and align pump connections as dictated by your overall system design.
2. Connect the suction check valve to a gravity-fed chemical source. This pump requires a flooded suction. We recommend installation of filters to the suction of each Liquid End and some form of pump inlet isolation. Warranty may be affected if you do not.
3. Connect the discharge check valve to the process line. We recommend installation of a pressure relief valve to the discharge of each Liquid End. Warranty may be affected if you do not.
4. Check that the pump adaptor ring is firm.
5. Open the bleeder valve until chemical starts to flow then re-tighten.
6. Ensure that the DC power supply that you are using corresponds to the DC power required. 12 volts supply to 12 volts equipment. 24 volts supply to 24 volts equipment

**WARNING:** Ensure the DC power supply to the DC Drive Motor is fused with the correct fuse. See Section 2.0 for details.

**WARNING:** For AC models, all AC equipment must be installed by licenced electrical personnel.

7. Before connecting the supply leads to the DC motor make ensure the supply is isolated.
8. Connect motor power leads to supply, Red to Red (+) and Black to Black (-).

If installing with an SIAT75001 Timer/Controller, connect the battery power supply and motor leads to the four screw terminals clearly marked and located on the lower front face of the timer.

**WARNING:** Connecting the main power supply in the reverse polarity can cause immediate failure of the electronics within the timer module.

**WARNING:** As the control and isolation of the DC Drive is supplied by the operator, care must be taken in selecting equipment to carry out these functions. We recommend discussing alternative operator-designed control methods prior to installation.

# SECTION 3 PUMP OPERATION

## 3.0 Operating Pump with SiA Timer/Controller: SIAT75001

SIAT75001 SiA Smart Controller

Revision: TH1

# QUICK START GUIDE

Thank you for purchasing an SiA Smart Controller.

### INSTALLATION

#### Physical Installation

Use the DIN Rail mounts at the back of the controller to mount timer within a suitable enclosure.

Ensure the enclosure provides a dry, well-ventilated environment that prevents direct sunlight reaching timer.

**The SIAT75001 must not be installed or operated in a defined Hazardous Area.**

#### Important Information Before Connecting Power to the Controller

1. Ensure the correct rated fuse is installed in the Fuse Holder. Refer to Fuses Section for details
2. Ensure you have correctly wired the power connections to the Power Terminal Header (PTH).
3. Ensure only either 12 VDC or 24 VDC power is connected to the "IN" terminals.



**NOTE:**As the controller will always return to the state it was last in before power was disconnected, the timer could give an output to the Motor Terminals on the PTH immediately when the power is connected. To avoid this, fit an On/Off isolating switch between the timer's Motor Terminals on the PTH and the motor's terminals.

#### Fuses

It is very important that the correctly sized fuse is installed on the Controller. We suggest using Littlefuse ATO Automotive Quick Acting Fuses.

**Never use a fuse greater than 20 amps.**

Choose a fuse that is suited for the protection of other equipment within the electrical circuit (providing it calls for a fuse of no more than 20amps). Usually, the most important piece of equipment within the timer circuit is the DC Motor. To work out the appropriate fuse rating to protect the motor, refer to the data-plate attached to the motor. For SiA PMDC motors the following table is a guide:

Power (watts)	Voltage	Recommended Max. Fuse Rating
25	12	5
25	24	2
40	12	5
40	24	3
60	12	10
60	24	5

Power (watts)	Voltage	Recommended Max. Fuse Rating
90	12	10
90	24	5
120	12	15
120	24	7.5
HE	24	5

If the motor power selected requires a fuse greater than 15 amps, SiA recommends the use of a suitable relay that can carry the extra load required.



# SIAT75001 SiA Smart Controller

Revision: TH1

## OPERATION

First time connection of power (standard software & default settings)

It is important to review the default settings (see table below). Please note your controller may have been pre-programmed to your application's specifications.

Setting	Setting Purpose	Default Value	All Values
Units	The type of units used.	Metric	Metric; US
Power On State	Sets what happens to the Timer when power is applied.	Resume	
Mode	Sets the pump running conditions.	Auto	Cont - Pumps continuously Auto - Pumps to chosen Flow Rate Fixed - Pumps to chosen On/Off Times. Batch - Pumps to chosen On/Off Times at different times/days of week.
On Time	Sets the On Time (in seconds) used in Fixed Mode	2	1 - 60
Off Time	Sets the Off Time (in seconds) used in Fixed Mode	10	1 - 60
Flow Rate	Sets the desired flow rate in Auto Mode.	1.0 LPH	
Pump Size	Aligns the Timer with the pump size.	L25 1/4"	L15 1/8"                      L75 3/4" L25 1/4"                      L100 1" L35 3/8"                      L150 1 1/2" L50 1/2"                      L225 2 1/4"
Battery Voltage	Sets the battery voltage.	Auto	12V; 24V; AUTO
Low Power Voltage	Sets the battery voltage that will trigger Low Power Mode.	12.1	
Cut Out Voltage	Sets the battery voltage that will turn the pump off.	11.8	
Restore Voltage	Sets the battery voltage that will turn the pump back on after Cut Out.	11.9	
Power Save Percentage	Sets the percentage of the flow rate in Low Power Mode.	50	

## OPERATION (cont.)

### 4 Show Current Settings



1. Depress the '+' & '-' buttons until 'Show Settings' appears on the screen.
2. Depress "Select" button to cycle through settings.
3. Depress "Back" to exit.

### 5 Select Mode



1. Depress the '+' & '-' buttons until 'Mode Select' appears on the screen.
2. Depress "Select" button and cycle to required mode.
3. Depress "Select" again to select.
4. Depress the "Back" button to return to the "Start Timer" screen and start controller as per step 2.

### 6 Set Units

1. Ensure the controller has power on and the display shows as per **1** on the previous page.
2. Depress the '+' twice or until the display shows 'OPTIONS' and then depress the 'Select' button.
3. Depress the '+' or '-' buttons until the display shows 'UNITS' and then depress the 'Select' button.
4. Use the '+' or '-' buttons to choose either 'Metric LPH' or 'US GPH' and then depress the 'Select' button.
5. From here you can either depress the 'Back' button until the display shows as per **1** to start the controller or you can go on to set other parameters such as 'PUMP SIZE'; 'FLOW RATE'; or 'MODE SELECT'.

### 7 Set Pump Size

1. Ensure the controller has power on and the display shows as per **1** on the previous page.
2. Depress the '+' twice or until the display shows 'OPTIONS' and then depress the 'Select' button.
3. Depress the '+' or '-' buttons until the display shows 'PUMP SIZE' and then depress the 'Select' button.
4. Use the '+' or '-' buttons to get to the correct pump size (e.g 'L150 1 1/2" ') and then depress the 'Select' button.
5. From here you can either depress the 'Back' button until the display shows as per **1** to start the controller or you can go on to set other parameters such as 'UNITS'; 'FLOW RATE' or 'MODE SELECT'.

### 8 Set Flow Rate

1. Ensure the controller has power on and the display shows as per **1** on the previous page.
2. Depress the '+' twice or until the display shows 'OPTIONS' and then depress the 'Select' button.
3. Depress the '+' or '-' buttons until the display shows 'FLOW RATE...' and then depress the 'Select' button.
4. Use the '+' or '-' buttons to set your desired flow rate (in LPH or GPH depending on the UNITS selected previously), and then depress the 'Select' button.
5. From here you can either depress the 'Back' button until the display shows as per **1** to start the controller or you can go on to set other parameters such as 'UNITS'; 'PUMP SIZE' or 'MODE SELECT'.

OPERATION (cont.)

**1** Power On

LCD DISPLAY

Indicates operation

Clock



Battery Status

Voltage

When rotating, indicates Controller is running.

Full - normal state  
 Half - low power state  
 Empty - power cut state

**2** Start Timer



Depress 'Select' button to quick start Controller from this screen.

**3** Stop Timer



Depress the '+' button until you cycle to the 'Stop Timer' screen and then press 'Select'.

**Note:** This will stop the Controller at the next 'Pump Off' state ie if the pump is running when you are pressing the 'Select' button, it will continue until the pump is in an "off" state.

Alternate option for stopping the Timer:

1. Cycle to the 'Kill Timer' screen by pressing the '+' button and then press 'Select' to initiate the operation command. This will stop the Controller instantly, turning the pump off if it was on.

### 3.1 Chemical Injection Flow Rate Adjustment

There are two ways of adjusting the injection flow rate, 1) electronic variable flow and 2) stroke length adjustment .

The two methods can be used together to finely tune the flow rate.

#### 3.11 Electronic Variable Flow Adjustment

Depending on the type of electric motor selected, two types of electric variable flow control can be achieved. The cycles per minute (cpm) can be altered from maximum by either slowing the electric motor with an electronic variable speed control device or preferably by using a Cycle Timer to 'start', 'stop' and vary the 'stop' time of the electric motor. We recommend using a cycle timer as it is simpler, more cost effective, robust, capable of operating at more extreme ambients and has been found to use less energy per volume of chemical injected.

Solar Injection Australia manufactures a range of DC Timers, please contact us or an SiA Distributor for details.

#### 3.12 Stroke Length Adjustment

All drives, except those with a Duplex Liquid End configuration (ie 2 liquid ends on the 1 drive), are fitted with a mechanical stroke length adjustor that allows the operator to adjust the length of the stroke and therefore the output per cycle infinitely between 0% and 100% while the pump is running.

Simply twist the adjustor until the desired flow is achieved. The lock nut provided will hold the chosen setting.

An optional micrometer stroke adjustor is available on request.

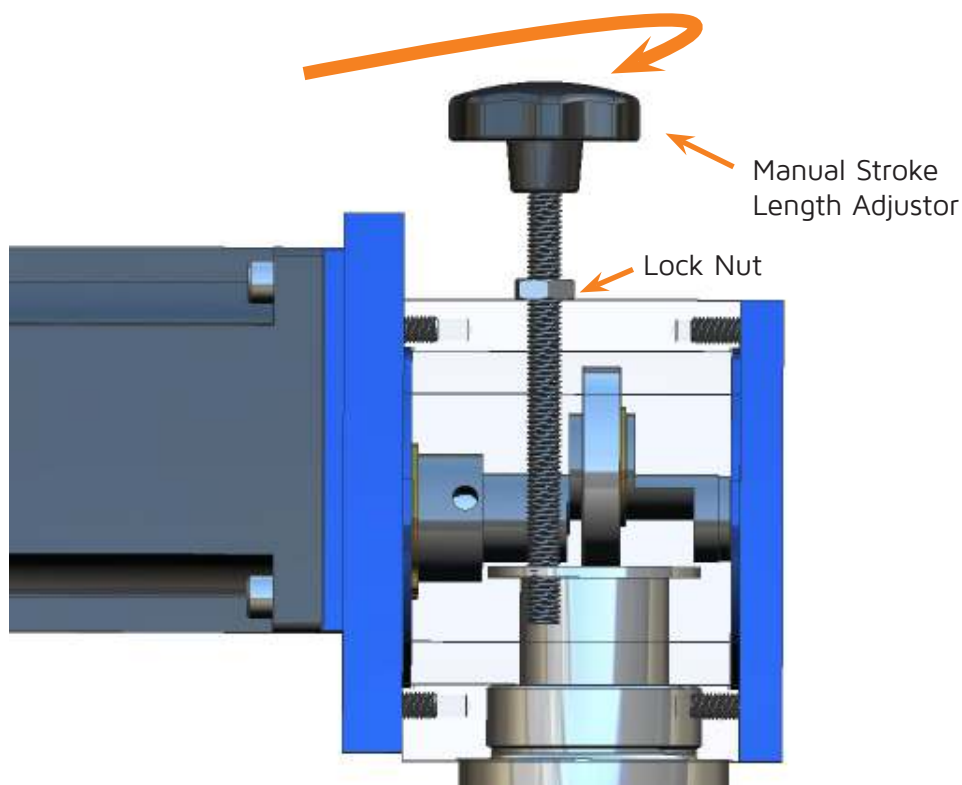

## SECTION 2 MAINTENANCE

### 4.0 Routine Maintenance: Drive Assembly

Providing the Drive Assembly is selected and installed correctly, the Drive should perform for a long period of time with little or no routine maintenance. We recommend however, that checks are made at least every 6 months. The only wearing parts of the Drive are the Bearings and the Plunger Adaptors.

#### 4.01 Bearings

Inspection of the bearings should take place regularly. If operating in clean and dry conditions we recommend 6 monthly inspections of moving parts. If operating in wet and/or dirty conditions, we recommend more frequent inspections, starting with monthly inspections until the operator is comfortable with longer service intervals.

To inspect bearings, follow these steps (refer to ILLUSTRATION & PARTS LIST, Page 2):

1. For Simplex pumps, ensure the Liquid End is facing downwards, so that no liquid runs into the Drive Case.
2. For all pump configurations unscrew the Pump Connection Ring by hand to loosen and remove the Liquid End/s.
3. Remove the Gearmotor or Gearbox by removing the 4 long screws attaching it to the Drive Case
4. Unscrew the Bearing End Plate by removing the 4 screws
5. Remove the Crank Shaft and Bearings and inspect. You may need to move the Plunger Adaptor/s to enable you to do this.

**WARNING:** Should the bearings become worn in any way they should be replaced immediately with new parts available from Solar Injection Australia or SiA Distributors.

6. Place the Crank Shaft and Bearings (or replacement Bearings) into the Drive Case
7. Place the Bearing End Plate back on the Drive Case and secure with the 4 screws
8. Reattach the Liquid End/s and tighten the Pump Connection Ring/s. You may need to carefully push down and hold the Plunger into the Liquid End to enable you to do this.
9. Position the Gearmotor or Gearbox back on the Drive Case and secure with the 4 screws.

All three Precision Roller Bearings are sealed type and do not require in-field lubrication. They have been selected using design loads far in excess of the loads that should be generated by the design limitations of the product. Providing no moisture or dirt penetrates and that the Drive is used in accordance with its design parameters a long life can be expected.

#### 4.02 Plunger Adaptors

We have both Ertalyte and stainless steel versions of our Plunger Adaptors. No grease is applied on assembly and providing abrasive dirt does not come between the Cam Bearing and the Plunger Adaptor, negligible wear should take place through millions of cycles. If replacing Plunger Adaptor/s, ensure you replace like for like as Ertalyte and stainless steel versions are not interchangeable.

To inspect Plunger Adaptor/s follow the steps outlined above for inspecting Bearings. After step 5, remove and inspect Plunger Adaptor/s and then replace and continue to follow steps 6—9.



## 4.1 Routine Maintenance: SiA Liquid Ends

The maintenance of any Chemical Injection Pump (CIP)/Liquid End, other than an SiA unit is not covered in this document.

**WARNING:** Solar Injection Australia accepts no responsibility should a Liquid End be fitted to an SiA Drive without first seeking a recommendation from SiA to ensure correct matching of the Gearmotor, Drive and Liquid End (pump).

### 4.10 Pressure Seal Grease

Check main pressure seal grease periodically and refill when necessary. This is done by removing the Lube Plug on the side of the Liquid End and if required, injecting a small quantity of SiA approved grease.

**CAUTION:** If injecting chemicals that cause the lubricant to foam, select an alternative lubricant compatible with the injected fluid. When it is essential that the injected chemical must have a high level of purity, use distilled water as the lubricant.

### 4.11 Injection Chemicals

Ensure the chemicals being injected are clean and free of foreign matter to prevent damage to the seal and the Liquid End's plunger assembly. We recommend the installation of a suitable chemical filter.

### 4.12 Seals

Check the seals regularly. Seal material and chemical compatibility is paramount. Our standard plunger seal (TS) is a specially formulated PTFE and stainless steel compound that is energized with a Viton o'ring, which is compatible with most chemicals, however we do have numerous alternative materials available, please consult Solar Injection Australia or an SiA Distributor for further assistance with choosing the right seal or when changing the chemicals you are injecting.

To inspect Seals & Back Ups follow these steps (refer to ILLUSTRATION & PARTS LIST, Page 2):

1. For Simplex pumps, ensure the Liquid End is facing downwards, so that no liquid runs into the Drive Case.
2. For all pump configurations unscrew the Pump Connection Ring by hand to loosen and remove the Liquid End/s.
3. Carefully remove the Plunger section and place gently on a flat surface.
4. Remove the Flange and the Pump Connection Ring
5. Unscrew the three parts of the Pump Body (Upper, Middle, Lower)
6. Very carefully remove the Back Ups and Seals using either the plunger or a brass or plastic pick. To use the plunger, insert it into the pump body below the seal and push the seal and back up out. To use the pick, hook the seal and back up carefully and pull them out.

**CAUTION:** Be very careful not to damage the seal or other surfaces when extracting.

7. Replace the Seals and Back ups and then Follow Steps 1– 5 in reverse to complete.



## 4.2 Routine Maintenance: Gearmotors fitted to the Drive

Generally, the gearmotor does not require routine maintenance other than periodic brush replacement on our Standard DC models. Apart from these brushes there are no service parts available. Should the DC gearmotor fail (or separately the motor or gearbox), we recommend the whole DC gearmotor be replaced with a new unit, available from Solar Injection Australia or an SiA distributor.

We recommend that the brushes be inspected as often as practical until the operator obtains experience of the expected brush life for each situation, but at least every 6 months.

Note: There are no brushes in a BLDC Motor.

To inspect and or replace brushes on our Standard PMDC Gearmotor models, please follow the steps below:

1. Disconnect power to pump before any servicing takes place.
2. Use large flat blade screwdriver to unthread the plastic caps on either side of the motor.
3. Remove the brushes carefully (they are spring loaded).
4. Examine them. They should be at least 1/8" thick. If they are not, replace them. They will not last much longer.
5. Replace new brushes into the holes on either side of the motor's outer shell and rethread the plastic caps.
6. As with the moving internals of the Drive, the operator can expect longer service intervals and life by keeping the gearmotor clean and dry.

**WARNING:** Should the gearmotor show signs of wear in any way it should be replaced immediately with new parts available from Solar Injection Australia or SiA Distributors.

### 4.3 Corrective Maintenance

Situation	Cause	Resolution
NO PUMP DISCHARGE	<ul style="list-style-type: none"> <li>• Suction &amp;/or discharge check valves not seating</li> <li>• Pump vapour locked</li> <li>• Suction or discharge line plugged/blocked</li> </ul>	<ul style="list-style-type: none"> <li>• Clean or replace suction &amp;/or discharge check valves</li> <li>• Open bleed plug &amp; prime</li> <li>• Check for closed isolating valve</li> <li>• Check inlet and discharge lines for blockage</li> </ul>
PUMP DOES NOT CYCLE	<ul style="list-style-type: none"> <li>• Plunger stuck due to tight or dry seal</li> <li>• Process line pressure too high for unit selected</li> <li>• Blown fuse</li> <li>• No power supply to DC motor drive</li> <li>• Timer switch in OFF position</li> <li>• Timer set to minimum cycle rate</li> </ul>	<ul style="list-style-type: none"> <li>• Check seal, if swollen , check chemical compatibility and replace</li> <li>• Check selection and ensure discharge line is not blocked</li> <li>• Check and replace fuse in DC supply. If this condition repeats itself, check the drive mechanism for seizure.</li> <li>• Check and connect correct power supply</li> <li>• Set switch to CONTINUOUS for testing</li> <li>• Adjust timer accordingly</li> </ul>
SHORT SEAL LIFE	<ul style="list-style-type: none"> <li>• Nick, Burr or scratches on plunger</li> <li>• Seal &amp;/or plunger materials not compatible with chemical being injected</li> <li>• Lack of lubricant</li> <li>• Incorrect lubricant or chemical crystallising on plunger and scoring seal/plunger</li> </ul>	<ul style="list-style-type: none"> <li>• Replace plunger</li> <li>• Refer to chemical compatibility charts or contact Solar Injection Australia</li> <li>• Maintain visible lubricant level in reservoir.</li> <li>• Change lubricant to be compatible with chemicals being pumped.</li> </ul>

# APPENDIX: CHEMICAL COMPATIBILITY CHART

Corrosive Agent	Steel	304 SS	316 SS	C-20	Teflon	PVC	Viton	Buna-N	Fluoraz
Acetaldehyde	B	A	A	A	A	C	C	B	C
Acetate Solvents	B	A	A	A	A	C	C	C	C
Acetic Acid, 20%	B	A	A	A	A	A	C	A	C
Acetic Acid Concentrated to 150°F(66° C)		B	A	A	A	C	C		C
Acetic Acid Concentrated to 212°F(100 C)	C	B	A	A	A	C	C	C	
Acetic Anhydride	C	B	A	A	A	C	C	A	C
Acetone	B	A	A	A	A	C	C	B	C
Alum	C	C	B	A	A	A	A	A	A
Aluminum Chloride	C	C	C	B	A	A	A	A	A
Aluminum Nitrate	B	A	A	A	A	A	A		
Aluminum Sulfate	C	C	B	A	A	A	A	A	A
Ammonia Anhydrous	A	A	A	A	A		C	A	A
Ammonium Bicarbonate	A	A	A	A	A	A	A		C
Ammonium Bisulfite	B	A	A	A	A	A	A		
Ammonium Bifluoride	C	B	B	A	A		A		A
Ammonium Hydroxide	C	A	A	A	A	A	B	A	A
Ammonium Nitrate	B	A	A	A	A	A		B	C
Ammonium Phosphate	C	B	A	A	A	A	A	A	
Ammonium Sulfate	C	B	B	B	A	A	A	A	C
Ammonium Sulfite	C	A	A	A	A	A	A		
Amyl Acetate Dry	A	A	A	A	A	C	C	C	C
Amyl Alcohol	A	A	A	A	A	B	A	A	B
Amyl Chloride	C	B	A	A	A	C	C	C	
Aniline Chloride	C	B	A	A	A		B		
Aniline Dyes	C	A	A	A	A	C	B	C	
Animal Fats and Oils		A	A	A	A	A	A	C	A
Aqua Regia	C	C	C	C	A		B	C	
Ascorbic Acid	C	A	A	A	A				
Barium Chloride	C	C	C	B	A	A	A	A	A
Barium Sulfite	B	A	A	A	A	A	A	A	
Benzaldehyde	B	A	A	A	A	C	C	C	
Benzene	A	A	A	A	A	C	B	C	C
Benzene Sulfonic Acid 10%	C	B	B	A	A	A	A	C	C
Benzoic Acid	C	B	B	A	A	A		C	A
Benzoyl Chloride	C	C	C	C	A		B		
Boric Acid	C	A	A	A	A	A	A	A	A
Bromine Anhydrous	C	C	C	B	A	C	A	C	C
Bromine Dilute	C	C	C	C	A	B	A	C	C
Bromine Trifluoride	C	C	B	B	A		C		C
Butadiene	C	A	A	A	A		A		C
Butane	B	A	A	A	A	A	A	A	A
Butyric Acid 20%	C	A	A	A	A		C	A	A
Butyric Acid, Concentrated	C	B	B	B	A		C		A
Calcium Bisulfite	B	A	A	A	A	A	A	A	A
Calcium Carbonate	A	A	A	A	A	A	A	A	A
Calcium Chlorate	C	A	A	A	A	A	A	A	A
Calcium Chloride	C	B	B	A	A	A	A	A	A
Calcium Hydroxide	A	A	A	A	A	A	A	A	A
Calcium Hypochlorite	C	C	C	C	A	A	A	C	A
Calcium Nitrate	C	A	A	A	A	A	A		
Calcium Sulfite	C	A	A	A	A	A	A		
Calcium Sulfate		A	A	A	A	A	A	C	
Camphor Alcohol Sol	B	A	A	A	A				
Carbon Disulfide	C	A	A	A	A		A	C	
Carbon Tetrachloride Dry	B	A	A	A	A	C		C	
Carbon Tetrachloride Wet	C	B	B	B	A	C		C	C
Carbon Water Slurries	C	B	A	A	A	A	A	A	
Cesium, 260°F(127°C)	C	A	A	A	A	C	C		
Chlorine, Anhydrous	A	A	A	A	A		C	C	C
Chlorine Water	C	C	C	A	A	A	A	C	C
Chloroacetic Acid	C	C	C	C	A		C		C
Chlorobenzene	C	A	A	A	A	C	A		B
Chloroform	B	A	A	A	A	C	A		C
Chlorosulfonic Acid	C	B	B	B	A	C	C	C	B
Choline Chloride	A	A	A	A					
Chromic Acid to 150°F(66°C)	C	B	B	B	A			C	A
Citric Acid	C	B	B	A	A	A	A	A	A
Copper Chloride	C	C	C	C	A	A	A	A	A
Copper Fluoride	C	B	B	B	A	A			

Key to Rating: A - Substantial Resistance, B - Moderate Resistance, C - Severe Effect, Blank - No Data



# CHEMICAL COMPATIBILITY CHART (continued)

Corrosive Agent	Steel	304 SS	316 SS	C-20	Teflon	PVC	Viton	Buna-N	Fluoraz
Copper Nitrate	C	B	A	A	A	A	A	A	A
Copper Sulfate	B	A	A	A	A	A	A	A	A
Cottonseed Oil	A	A	A	A	A	A	A		A
Creosols	A	A	A	A	A	C	C	C	A
Cyclohexane	B	A	A	A	A	C	A	C	A
Cyclohexanone	B	A	A	A	A	C	C	C	B
Dichlorethane, Dry	A	A	A	A	A	C		C	C
Diethanolamine	A	A	A	A	A	C	C		A
Diethyl Benzene	A	A	A	A	A	C			
Diethyl Ether	A	A	A	A	A		C		C
Diethyl Sulfate	C	B	B	A	A				
Diethylene Glycol	B	A	A	A	A		A	A	A
Dimethyl Amine	A	A	A	A	A	C			
Dimethyl Phthalate	A	A	A	A	A	C	C		B
Ether	A	A	A	A	A	C	C		C
Ethyl Acetate	A	A	A	A	A	C	C	C	C
Ethyl Alcohol	A	A	A	A	A	A	C		A
Ethyl Benzene	A	A	A	A	A		A		C
Ethyl Bromide	C	C	C	C	A	C			
Ethyl Chloride	C	A	A	A	A	C	A	C	A
Ethyl Mercaptan	B	A	A	A	A	C	A		C
Ethylene(Liquefied)	A	A	A	A	A				
Ethylene Dichloride	C	A	A	A	A		B	C	A
Ethylene Glycol	B	A	A	A	A	A	A	A	A
Ethylene Oxide	C	A	A	A	A	C	C	C	C
Fatty Acids	C	A	A	A	A	A	A	A	
Ferric Chloride	C	C	C	C	A	A	A	A	A
Ferric Nitrate	C	B	B	A	A	A	A	A	
Ferric Sulfate	C	C	B	C	A	A	A	A	A
Ferrous Chloride	C	C	C	C	A	A	A	A	
Ferrous Sulfate	C	C	C	C	A	A	A	A	
Filter Aid Slurries B	A	A	A	A	A	A	A		
Fluosilicic Acid	C	C	C	B	A	A	A	A	
Copper Fluoride	C	B	B	B	A	A			
Copper Nitrate	C	B	A	A	A	A	A	A	A
Copper Sulfate	B	A	A	A	A	A	A	A	A
Cottonseed Oil	A	A	A	A	A	A	A		A
Creosols	A	A	A	A	A	C	C	C	A
Cyclohexane	B	A	A	A	A	C	A	C	A
Cyclohexanone	B	A	A	A	A	C	C	C	B
Dichlorethane, Dry	A	A	A	A	A	C		C	C
Diethanolamine	A	A	A	A	A	C	C		A
Diethyl Benzene	A	A	A	A	A	C			
Diethyl Ether	A	A	A	A	A		C		C
Diethyl Sulfate	C	B	B	A	A				
Diethylene Glycol	B	A	A	A	A		A	A	A
Dimethyl Amine	A	A	A	A	A	C			
Dimethyl Phthalate	A	A	A	A	A	C	C		B
Ether	A	A	A	A	A	C	C		C
Ethyl Acetate	A	A	A	A	A	C	C	C	C
Ethyl Alcohol	A	A	A	A	A	A	C		A
Ethyl Benzene	A	A	A	A	A		A		C
Ethyl Bromide	C	C	C	C	A	C			
Ethyl Chloride	C	A	A	A	A	C	A	C	A
Ethyl Mercaptan	B	A	A	A	A	C	A		C
Ethylene(Liquefied)	A	A	A	A	A				
Ethylene Dichloride	C	A	A	A	A		B	C	A
Ethylene Glycol	B	A	A	A	A	A	A	A	A
Ethylene Oxide	C	A	A	A	A	C	C	C	C
Fatty Acids	C	A	A	A	A	A	A	A	
Ferric Chloride	C	C	C	C	A	A	A	A	A
Ferric Nitrate	C	B	B	A	A	A	A	A	
Ferric Sulfate	C	C	B	C	A	A	A	A	A
Ferrous Chloride	C	C	C	C	A	A	A	A	
Ferrous Sulfate	C	C	C	C	A	A	A	A	
Filter Aid Slurries B	A	A	A	A	A	A	A		
Fluosilicic Acid	C	C	C	B	A	A	A	A	
Formaldehyde,80°F(27°C),Rm. Temp	B	B	A	A	A	B	A	A	C
Formic Acid,80°F(27°C)	C	B	A	A	A	B	B	C	A

Key to Rating: A - Substantial Resistance, B - Moderate Resistance, C - Severe Effect, Blank - No Data

# CHEMICAL COMPATIBILITY CHART (continued)

Corrosive Agent	Steel	304 SS	316 SS	C-20	Teflon	PVC	Viton	Buna-N	Fluoraz
Freons, 80°F(27°C)	B	A	A	A	A			C	C
Fuel Oil	A	A	A	A	A	A	A	C	A
Furfural	B	A	A	A	A	C	C	C	A
Furfural Alcohol	B	B	B	A	A	C	C	C	
Gallic Acid,5%	C	B	B	B	A	A	A	B	
Gasoline	A	A	A	A	A		A	C	B
Glucose	A	A	A	A	A	A	A	A	A
Glycerine	B	A	A	A	A	A	A	A	A
Heptane	B	A	A	A	A	C	A	B	C
n-Hexane	B	A	A	A	A	C	A	B	
Hydrazine,35% and above	C	A	B	B	A	C	C	B	A
Hydrobromic Acid	C	C	C	C	A	B	A	C	A
Hydrochloric Acid,37%	C	C	C	C	A	A	A	C	A
Hydrocyanic Acid	C	A	A	A	A	A	A	C	A
Hydrofluoric Acid to 48%	C	C	C	C	A	A	A	C	A
Hydrogen Chloride Dry	A	A	A	A	A				
Hydrogen Cyanide	B	A	A	A	A	A			
Hydrogen Fluoride-Anhydrous	C	C	C	C	A			C	A
Hydrogen Peroxide, 50%	C	A	A		A		C	C	C
Hydrogen Peroxide, 90%	C	A	A		A	C	C	C	C
Hydrogen Sulfide	C	B	B	B	A	A		A	A
Hydroquinone	A	A	A	A	A	A	C		
Hypo(Sodium Thiosulfate)	C	B	A	A	A	A	A		
Iodine Solution, 5%	C	C	C	C	A	C	A	C	A
Isopropyl Alcohol	A	A	A	A	A		A	A	A
Isopropyl Chloride Dry	B	A	A	A	A				C
Kerosene	A	A	A	A	A	A	A	C	B
Lactic Acid, 50% 80°F(27°C)	B	B	A	A	A	A	A	A	B
Lard Oil	A	A	A	A	A		A	C	A
Lead Acetate	B	A	A	A	A	A	C	A	C
Lead-Tetraethyl	B	A	A	A	A				
Magnesium Carbonate	A	A	A	A	A	A	A	A	
Magnesium Chloride	C	B	B	A	A	A	C	A	
Magnesium Nitrate	A	A	A	A	A	A	A	A	
Magnesium Sulfate	B	A	A	A	A	A	A	A	
Maleic Acid-Dilute	C	B	A	A	A	A	A	C	
Melamine Resins	C	B	B	B	A			C	
Mercaptans	A	A	A	A	A		A	C	
Mercuric Chloride, Sol	C	C	C	B	A	A	A		
Mercury	B	A	A	B	A	A	A	A	
Methyl Alcohol	A	A	A	A	A	A	C	A	
Methyl Celiosolve	A	A	A	A	A		C	B	
Methyl Formate	A	A	A	A	A		C		
Methylene Chloride	B	A	A	A		C	C	C	C
Methyl Ethyl Ketone	A	A	A	A	A	C	C	C	C
Monochloroacetic Acid 70 F (21 C)	C	B	B	B	A	A			
Morpholine	A	A	A	A	A		C		
Muriatic Acid	C	C	C	C	A	A	A	C	A
Mustard	C	B	A	A	A	A		A	A
Naphtha	B	A	A	A	A	A	A	C	A
Naphthalene, Molten	A	A	A	A	C	C	A	C	C
Nickel Carbonyl, Solution		B	A	A	A				
Nickel Chloride, Solution		B	B	B	A	A	A	A	A
Nickel Nitrate, Solution		A	A	A	A	A	A	A	
Nickel Sulfate Solution		B	A	B	A	A	A	A	A
Nitric Acid to conc.-Rm		A	A	B	A	C	A	C	B
Nitric Acid,Red Fuming,Rm		A	A	B	A	C	C	C	B
Nitro Benzene to 212°F(100°C)		B	A	A		C	B	C	A
Nitrous Acid, 5%		A	A	A	A				
Nitrogen Tetroxide		A	A	A	A		C		
Nitrochlorobenzene				A	A	C	A		
Oleic Acid		A	A	A		A	B	B	
Oleum-25%		B	A	A	A	C	B	C	
Olive Oil	A	A	A	A	A	A	A	C	
Oxalic Acid		B	B	A	A	A	A	B	
Paraffin-Molten	A	A	A	A	A				
Paraldehyde	A	A		A	A				

Key to Rating: A - Substantial Resistance, B - Moderate Resistance, C - Severe Effect, Blank - No Data

# CHEMICAL COMPATIBILITY CHART (continued)

Corrosive Agent	Steel	304 SS	316 SS	C-20	Teflon	PVC	Viton	Buna-N	Fluoraz
Pentane	A	A		A	A				A
Perfumes	A	A		A	A				
Phenol-Molten	B	B		B	A		C		A
Phosgene		A		A	A				
Phosphoric Acid,60 Free of HF	C	B		A	A			C	A
Phosphoric Acid, 75% Free of HF	C	B	B	A	A	A	A	C	A
Phosphorous-Molten		B	A	A	A			C	
Phosphorous Oxychloride	C				A				
Phosphorous Trichloride	C	A	A	A	A		A	C	A
Pine Oil	A	A	A	A	A		B		
Phthalic Anhydride		B	B	A	A				B
Potassium Chromate	A	A	A	A	A	A	A	A	
Potassium Bromide	C	B	B	A	A	A	A	A	A
Potassium Carbonate	B	A	A	A	A	A	A	A	A
Potassium Chlorate	B	A	A	A	A	A	A	A	A
Potassium Chloride	C	B	B	A	A	A	A	A	A
Potassium Dichromate	B	A	A	A	A	A	A		A
Potassium Ferrocyanide	B	A	B	A	A	A	A		
Potassium Hydroxide	B	B	A	A	A	A	B	B	A
Potassium Iodide	C	B	B		A	A	A		
Potassium Nitrate	A	A	A	A	A	A	A	A	A
Potassium Permanganate	C	A	A	A	A	A	A	A	A
Potassium Sulfate	B	A	A	A	A	A	A	A	A
Propane	A	A	A	A	A	A	A	B	A
Propylene Dichloride, Dry	B	A	A	A	A	C		C	
Propylene Glycol	A	A	A	A	A		A	C	A
Propylene Oxide	A	A	A	A	A		C	C	C
Pyrogallic Acid	B	A	A	A	A				
Quinoline		A	A	A	A				
Silver Nitrate		A	A	A	A	A	A	A	A
Sodium-Molten		A	A	A	C			C	
Sodium-Potassium, NaK Alloy		A	A		C				
Sodium Acetate		B	A	A	A	A	C	B	C
Sodium Aluminate	B	A	A	A	A	A	B	A	A
Sodium Bicarbonate	B	A	A	A	A	A	A	A	A
Sodium Bichromate	B	A	A	A	A	A	A		
Sodium Bifluoride Slurry		A	A	A			C		
Sodium Bisulfate		B	A	A	A	A	A	A	A
Sodium Bisulfite	B	A	A	A	A	A	A	A	A
Sodium Borate	B	A	A	A	A	A	A	A	A
Sodium Bromide	C	B	B	A	A	A	A	A	
Sodium Carbonate	B	A	A	A	A	A	A	A	A
Sodium Chlorate	C	B	B	A	A	A	A	A	
Sodium Chloride	C	B	B	A	A	A	A	A	A
Sodium Chlorite	C	C	C	C	A	A	A	C	
Sodium Citrate	B	A	A	A	A	A			
Sodium Cyanide	B	A	A	A	A	A	A	A	C
Sodium Dichromate	A	A	A	A	A	B	A	B	
Sodium Ferricyanide, 5%	B	A	A	A	A	A	A	B	
Sodium Fluoride	C	C	B	B	A	A	A	C	
Sodium Hydroxide, 50%	A	A	A	A	A	A	B	B	A
Sodium Hydroxide, 73%	B	B	B	B	A		C	B	A
Sodium Hypochlorite, 5%	C	C	C	C	A	A	A	C	B
Sodium Hypochlorite, 20%	C	C	C	C	A	A	B	C	A
Sodium Metaphosphate	B	A	A	A	A	A	A	B	A
Sodium Nitrate	B	A	A	A	A	A	A	A	C
Sodium Nitrite		B	A	A	A	A	A	A	
Sodium Peroxide	C	A	A	A	A		A	A	A
Sodium Silicate	B	A	A	A	A	A	A	A	A
Sodium Sulfate	A	A	A	A	A	A	A	A	A
Sodium Sulfite		A	A	A	A	A	A	A	A
Sodium Thiosulfate (Hypo)	C	B	B	A	A	A	A	A	
Stannic Chloride	C	C	C	B	A	A	A	C	
Stannous Chloride		B	A	A	A	A	A	A	
Stearic Acid		A	A	A	A	A	A	B	A
Styrene		A	A	A	A		C	C	
Sulfamic Acid				B	A			B	

Key to Rating: A - Substantial Resistance, B - Moderate Resistance, C - Severe Effect, Blank - No Data

## CHEMICAL COMPATIBILITY CHART (continued)

Corrosive Agent	Steel	304 SS	316 SS	C-20	Teflon	PVC	Viton	Buna-N	Fluoraz
Sulfur-Molten		A	A	A	A		C		B
Sulfur Chloride		C	C	A	A		C	C	C
Sulfur Dioxide Dry	A	A	A	A	A			C	A
Sulfan	C	B	A	A	A		C		
Sulfur Trioxide	C	B	A	A	A		C		A
Sulfuric Acid below 93%	C	C	C	A	A	B	A	C	A
Sulfuric Acid-Commercial Concentrated	C	C	A	A	A	C	A	C	A
Sulfuric Acid, Fuming, 20%		B	A	A	A	C	B	C	A
Sulfurous Acid		B	B	A	A	A	A		
Tannic Acid, 10%		A	A	A	A	A	A	A	A
Tartaric Acid		B	A	A	A	A	A	A	A
Thionyl Chloride	C	C	B		A	C			
Titanium Dioxide Slurry	B			A	A	A	A	A	
TitaniumTetrachloride, Dry	A	A	A	A	A		A	B	C
Toluene	A	A	A	A	A	C	B	C	C
Tributyl Phosphate	B	A	A	A	A	C	C	C	
Trichloroethylene, Dry	A	A	A	A	A	C	A	C	
Tricresyl Phosphate	B	A	A	A	A	C	B	C	A
Triethanolamine		A	A	A	A	B	C	A	A
Trisodium Phosphate, Sol	B	A	A	A	A	A	A	A	A
Tung Oil	A	A	A	A	A		A		
Turpentine	A	A	A	A	A	A	A	C	A
Urea Formaldehyde	A	A	A	A	A				
Vegetable Oils	A	A	A	A	A	A	A	C	A
Uranium Nitrate		A	A	A	A				
Vinyl Acetate		A	A	A	A		C	C	
Vinylidene Chloride		A	A	A	A				A
Vinylidene Fluoride	B	A	A	A	A				
Xylene		A	A	A	A	C	C	C	C
Zinc Oxide Slurry	B	A	A	A	A	A	A	A	
Zinc Sulfate	B	A	A	A	A	A	A	A	A
Zinc Chromate		A	A	A	A	A	A		

Key to Rating: A - Substantial Resistance, B - Moderate Resistance, C - Severe Effect, Blank - No Data

# Solar Injection Australia

Specialising in chemical injection pump technology for the oil and gas industry, Solar Injection is a leading design and manufacturing business focused on delivering innovative, quality solutions.

Our approach is to innovate rather than imitate. The SiA brand of high quality and highly efficient pumps includes solar-powered; pneumatic/gas; and AC chemical injection pumps that are suitable for a wide range of applications, including hazardous area, sour gas and where other specialist requirements are needed. Our timers, controllers and detection accessories give our customers unparalleled control of the pumps both onsite and remotely (via SCADA).

With our network of distributors, we design and deliver customised solutions throughout the world – emerging now as a leader in unconventional energy.



## Quality

Quality in everything we do and the materials we use.



## Experience

Experience you can rely on with 30+ years in Oil & Gas.



## Innovation

Innovation rather than imitation.

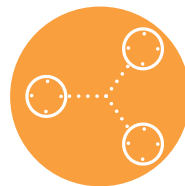

## Distribution

Distribution - providing local experience and expertise.

---

SIA DISTRIBUTOR:

---

CONTACT US FOR FURTHER INFORMATION



+61 7 3277 8822



sales@solarinjection.com.au



592 Tarragindi Rd, Salisbury,  
QLD 4107 Australia



**Solar Injection**  
**AUSTRALIA**

[www.solarinjection.com.au](http://www.solarinjection.com.au)